

General Instructions

Please retain product label and instructions for future reference

03TGCOR0808-V4

8x8 Corner Summerhouse

BEFORE YOU START PLEASE READ INSTRUCTIONS CAREFULLY

- Check the pack and make sure you have all the parts listed.
- When you are ready to start, make sure you have the right tools at hand (not supplied) including a Phillips screwdriver, Stanley knife, wood saw, step ladder and drill with 2mm bit.
- Ensure there is plenty of space and a clean dry area for assembly.

TIMBER

As with all natural materials, timber can be affected during various weather conditions. For the duration of heavy or extended periods of rain, swelling of the wood panels may occur. Warping of the wood may also occur during excessive dry spells due to an interior moisture loss. Unfortunately, these processes cannot be avoided but can be helped. It is suggested that the outdoor building is sprayed with water during extended periods of warm sunshine and sheltered as much as possible during rain or snow.

Our buildings are pre treated with a water based treatment**; this only helps to protect the product during transit and for upto 3 months against mould. To validate your guarantee and ensure longevity of the product, it is ESSENTIAL the building is treated with a wood preserver within the first three months of assembly and thereafter in accordance with the manufactures recommendations. Care must be taken to ensure the product is placed on a suitable base.

BUILDING A BASE

When thinking about where the building and base is going to be constructed: Ensure that there will be access to all sides for maintenance work and annual treatment.

Ensure the base is level and is built on firm ground, to prevent distortion. Refer to diagrams for the base dimensions, The base should be slightly smaller than the external measurement of the building, i.e. The cladding should overlap the base, creating a run off for water. It is also recommended that the floor be at least 25mm above the surrounding ground level to avoid flooding.

TYPES OF BASE

- Concrete 75mm laid on top of 75mm hard-core.
- Slabs laid on 50mm of sharp sand.

Whilst all products manufactured are made to the highest standards of Safety and in the case of childrens products independently tested to EN71 level, we cannot accept responsibility for your safety whilst erecting or using this product.

Refer to the instructions pages for you specific product code



x2

All building's should be erected by two adults



Winter = High Moisture = Expansion
Summer = Low Moisture = Contraction



2mm Drill bit

For ease of assembly, you **MUST** pilot drill all screw holes and ensure all screw heads are countersunk.



CAUTION

Every effort has been made during the manufacturing process to eliminate the prospect of splinters on rough surfaces of the timber. You are strongly advised to wear gloves when working with or handling rough sawn timber.

****Protim Aquatan T5 (621)****

Your building has been treated with **Aquatan**.

Aquatan is a water-based concentrate which is diluted with water, the building as been treated by the correct application of Aquatan solution and then allowed to dry.

Aquatan is a decorative finish to colour the wood, which is applied industrially to timber fence panels and garden buildings.

Aquatan undiluted contains: boric acid, sodium hydroxide 32% solution, aqueous mixture of sodium dioctyl sulphosuccinat and alcohols: 2, 4, 6-trichlorophenol.

For assistance please contact customer care on: 01636 880514

**Mercia Garden Products Limited,
Sutton On Trent,
Newark,
Nottinghamshire,
NG23 6QN**

www.merciagardenproducts.co.uk

Overall Dimensions:

Length = 2553mm
Width = 2533mm
Height = 2118mm

Base Dimensions:

Length = 2553mm
Width = 2553mm

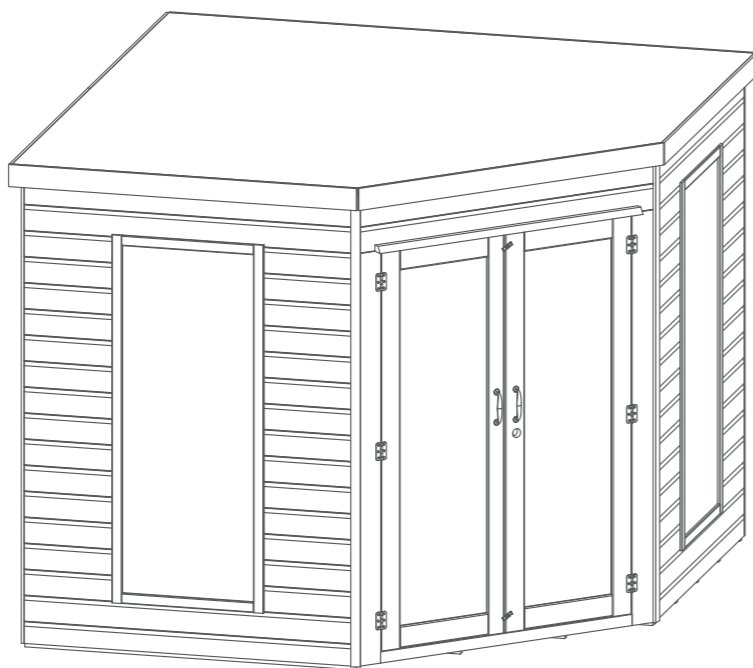

- 21** **Barrel Bolt QTY 2**
- 22** **Butt hinge QTY 6**
- 23** **Door Handle QTY 2**
- 24** **Turn Button QTY 2**
- 25** **Press Lock**
- 26** **"L" Bracket**
- 27** **Rain Guard - 687mm QTY2**
- 28** **Rear Cover Trim - 1909mm QTY2**
- 29** **Locating Block - 239mm QTY2**
- 27** **Rain Guard - 1260mm**

Nail Bag

- 40mm Screw x72**
- 50mm Screw x52**
- 60mm Screw x14**
- 35mm Coach Screw x4**
- Felt Tacks x100**
- 10mm Screw x10**
- 16mm Black Screw x8**
- 30mm Screw x6**
- 25mm Screw x38**

- 1** **Door Panel**
- 2** **Window Panel QTY 2**
- 3** **Rear Panel Right**
- 4** **Rear Panel Left**
- 5** **Floor**
- 6** **Angled Floor**

- 7** **Roof**
- 8** **Angled Roof**
- 9** **Master Door**
- 10** **Slave Door**
- 11** **Roof Support Bar - 2633mm**
- 12** **Roof Block - 300mm**
- 13** **Fascia - 1258mm QTY 4**
- 14** **Fascia - 1485mm QTY 3**
- 15** **Cover Trim - 2055mm QTY4**

- 16** **Rear Panel Frame - 2374mm**
- 17** **Front Panel Frame - 1411mm**
- 18** **Rear Roof Frame - 2517mm**
- 19** **Front Roof Frame - 1473mm**
- 20** **Panel Joint - 1918mm**

Pre Assembly

Remove transportation blocks from the bottom of each panel before beginning assembly. Each Panel should have two.

Attach the butt hinges to the door and door panel using 6x25mm screws per hinge.

36x25mm Screws

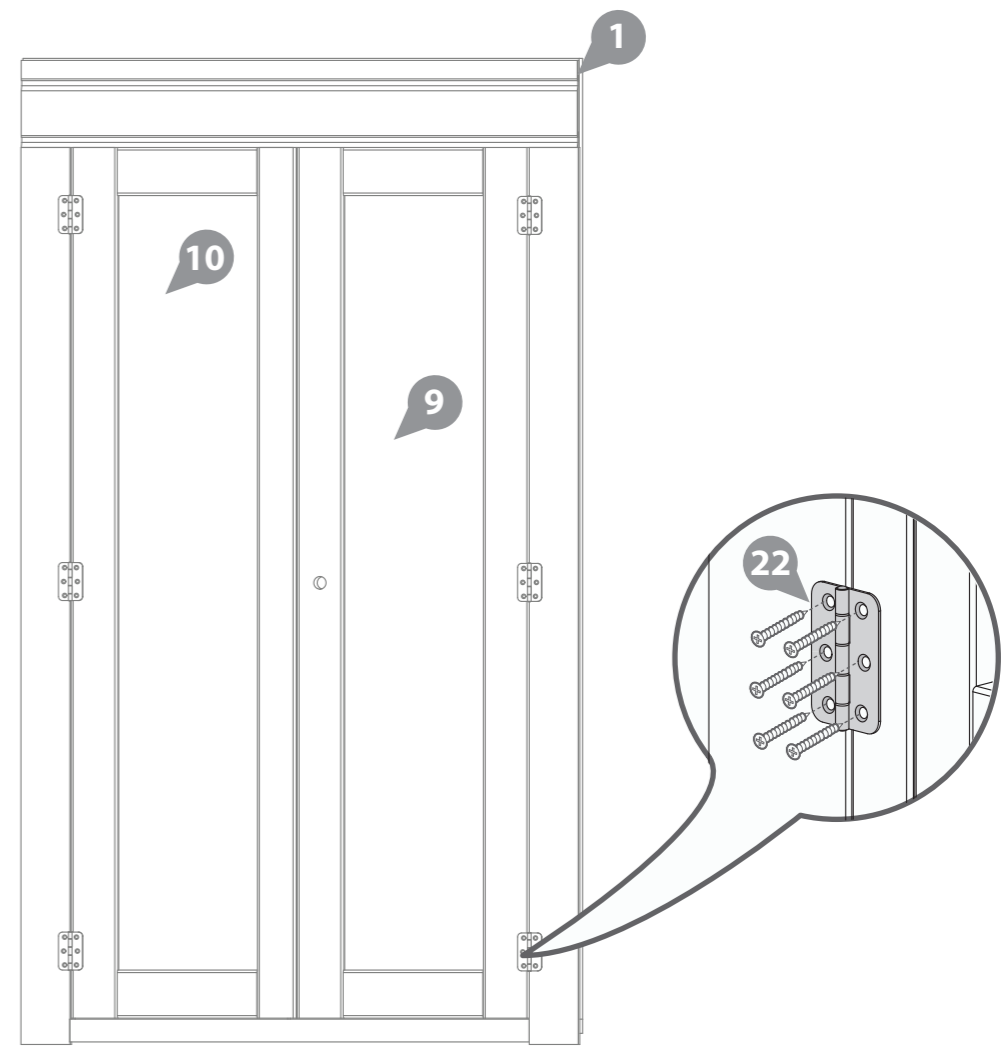

Pre Assembly

Position press lock on the door align with key hole and fix into position using 4 x 10mm screws.

Then fit barrel bolts to top and bottom of the door as shown in diagram. Use 4x10mm screws per barrel bolt.

Ensure doors open and close freely.

Drill a hole in the framing above and below the door for the tower bolt to fix into.

4x16mm Black Screws
8x10mm Screws



16mm screw



10mm screw

Pre drill holes then fix Chrome Handle using 35mm coach screw as shown in diagram.

4x35mm Bolt



35mm bolt

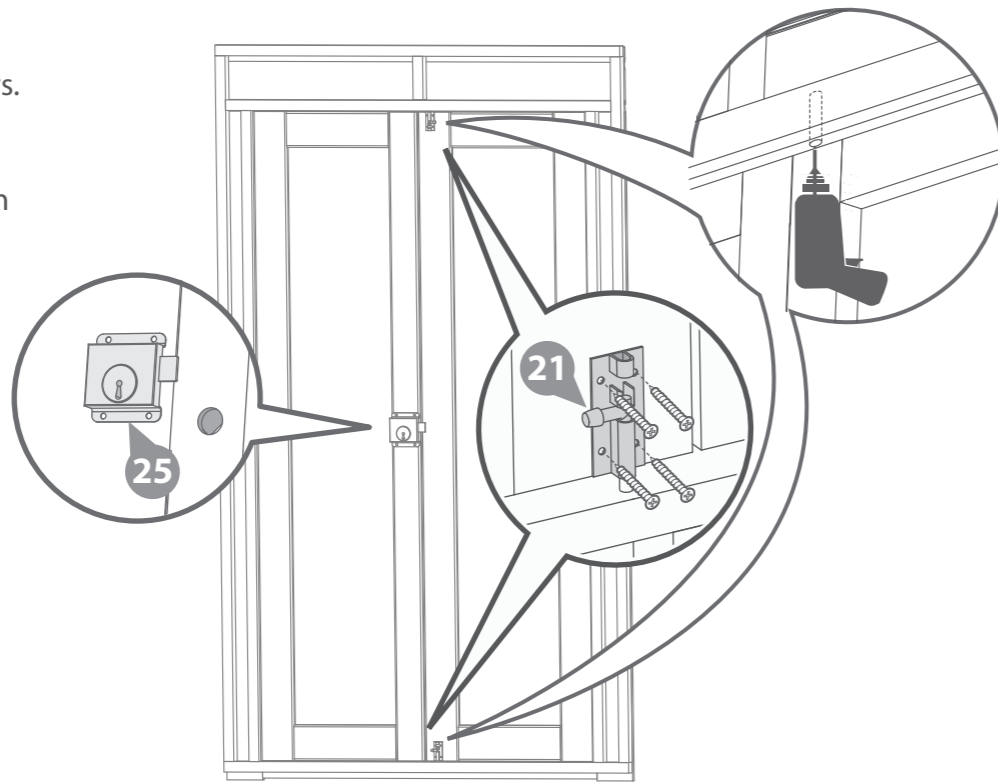

Wood is a natural product and is subject to movement with changing weather conditions. It is important that you fit the turn buttons and tower bolts as per the fitting instructions.

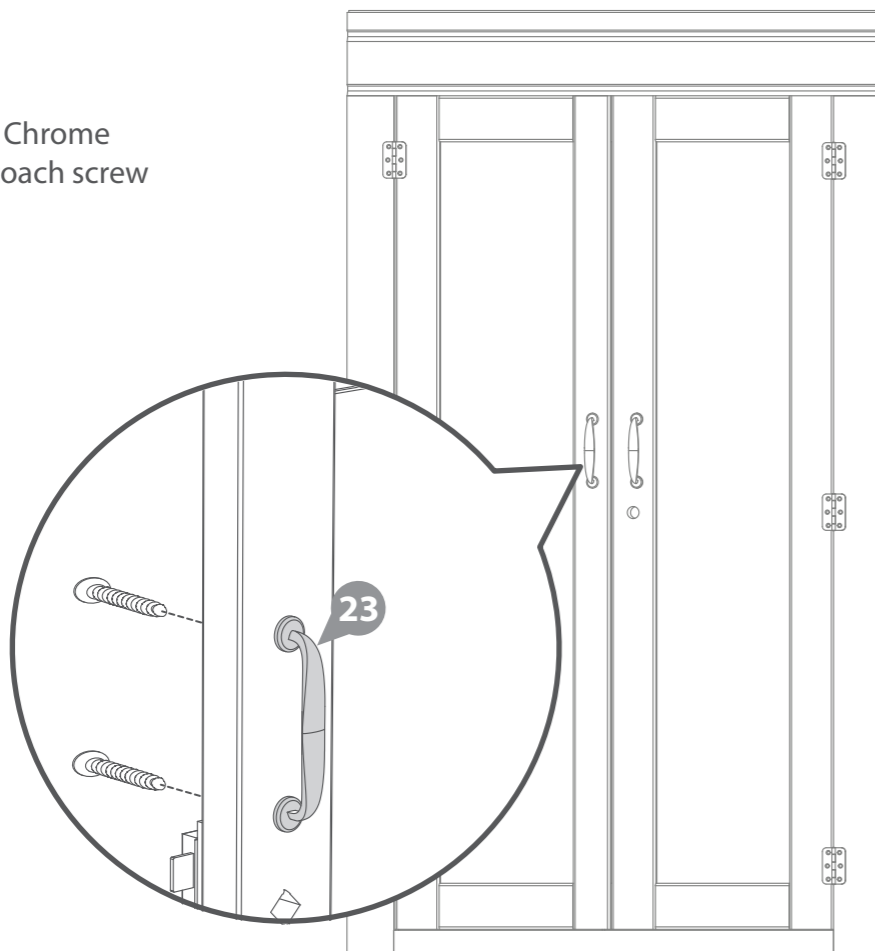

Step 1

First assemble the two floor panels as shown using 6x50mm screws.

Place floors on a firm and level base, ensure base has suitable drainage free from areas where standing water can collect. (See front page on base requirements).

6x50mm Screws



50mm screw

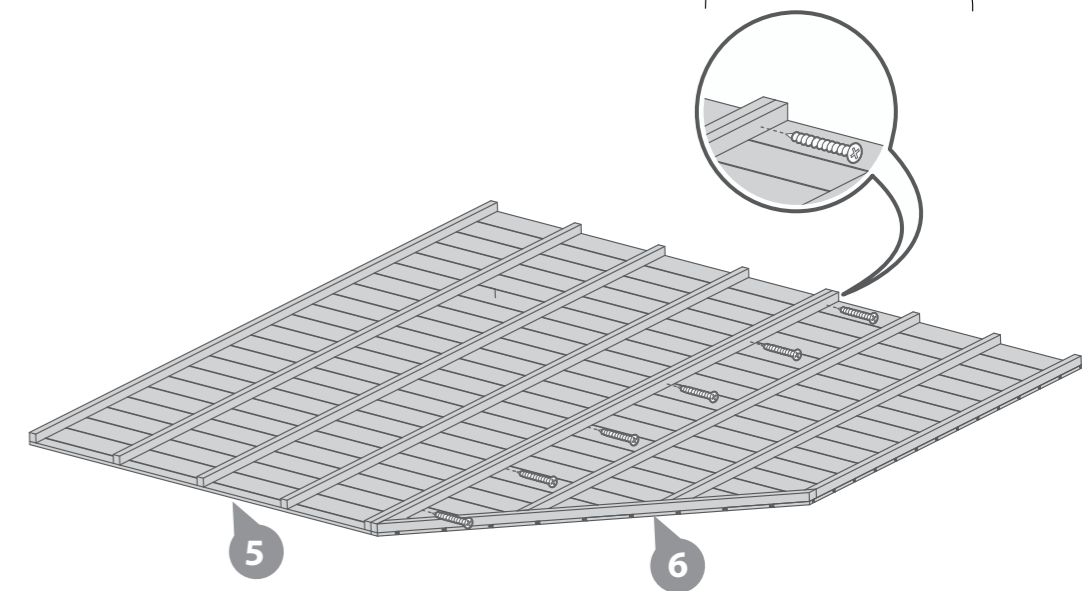

Step 2

Fix the window panels and the door panel at each corner using 6x60mm screws as shown in the diagram.

6x60mm Screws



60mm screw

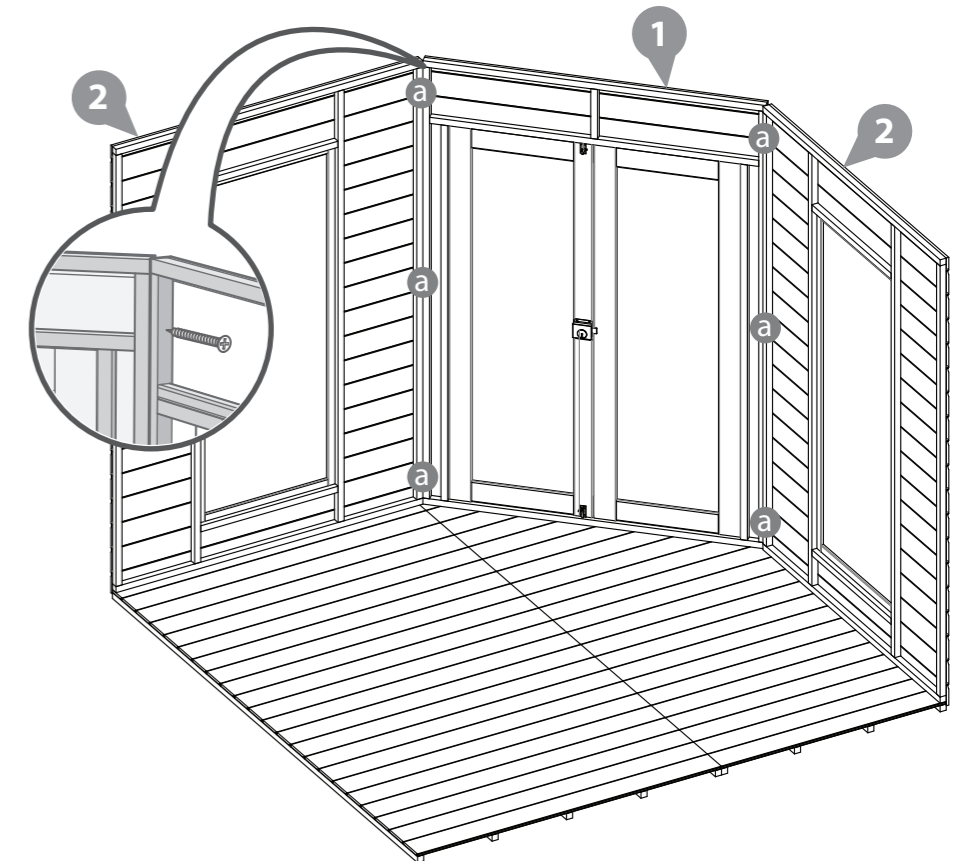

Step 3

Place the rear panel left against the floor and the window panel

a Fix the panels together with 3x50mm screws as shown in the diagram.

Attach the panel joint using 3x50mm screws.

6x50mm Screws

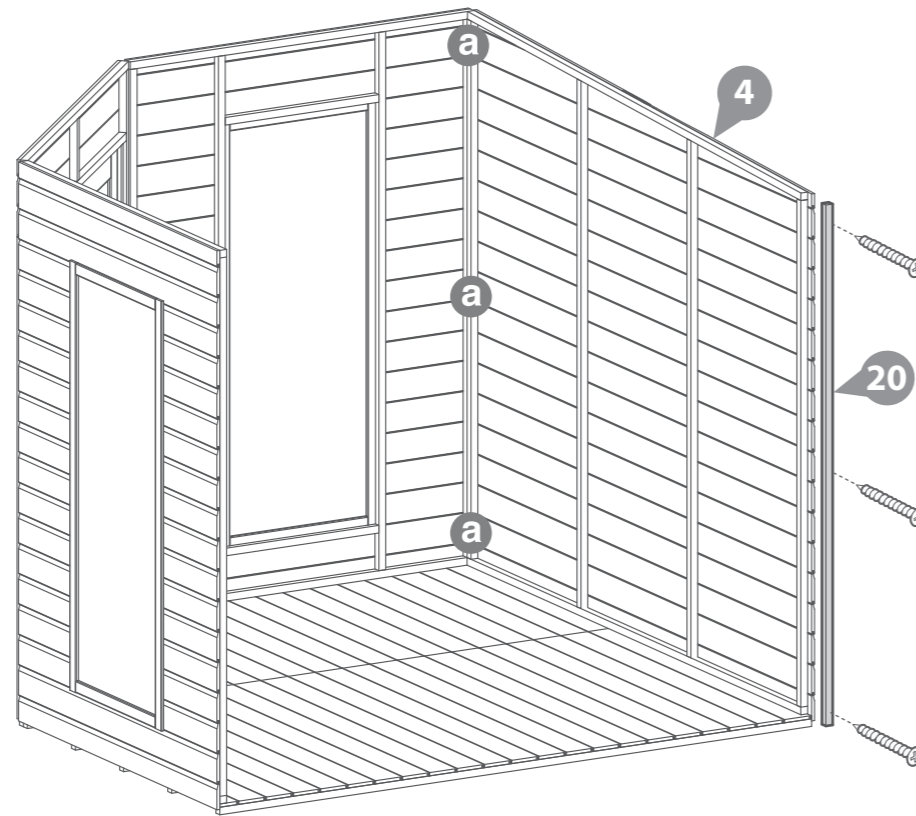

Step 5

Using 7x50mm screws, fix the front and rear panel frames to the top of the panels as shown in the diagram.

6x50mm Screws

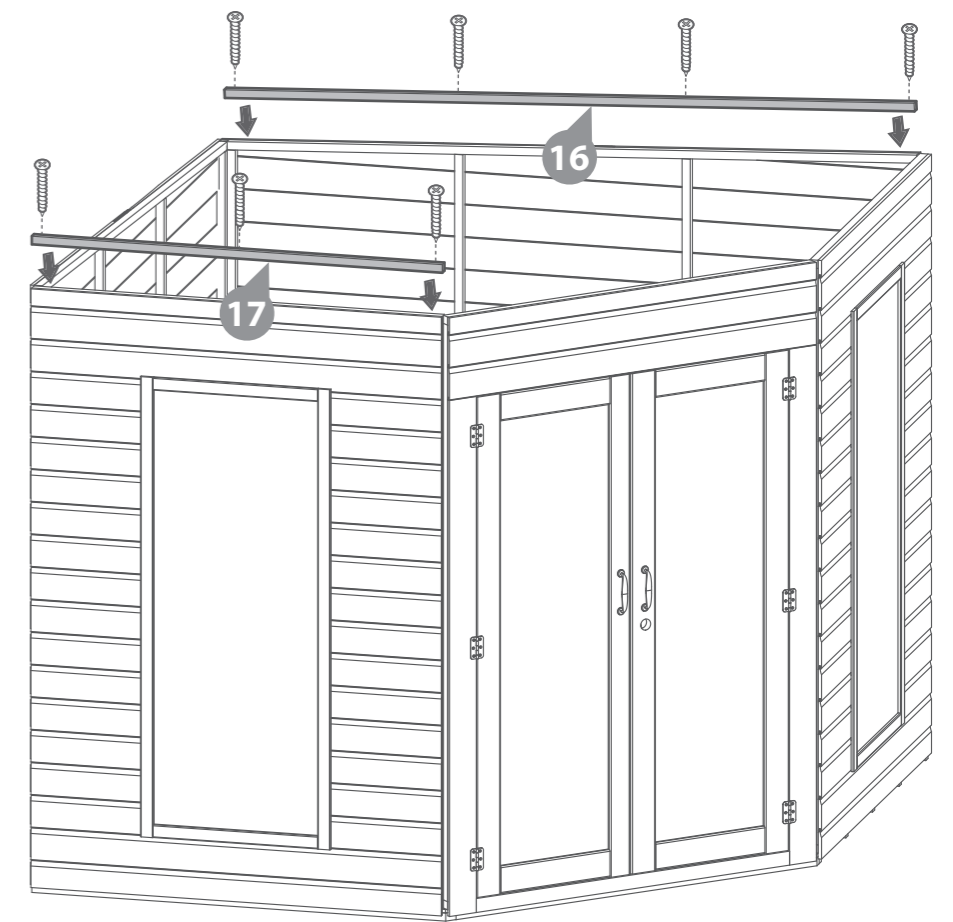

Step 4

a Following the same method outlined in step 3, attach the rear panel right to the building using 6x50mm screws.

6x50mm Screws

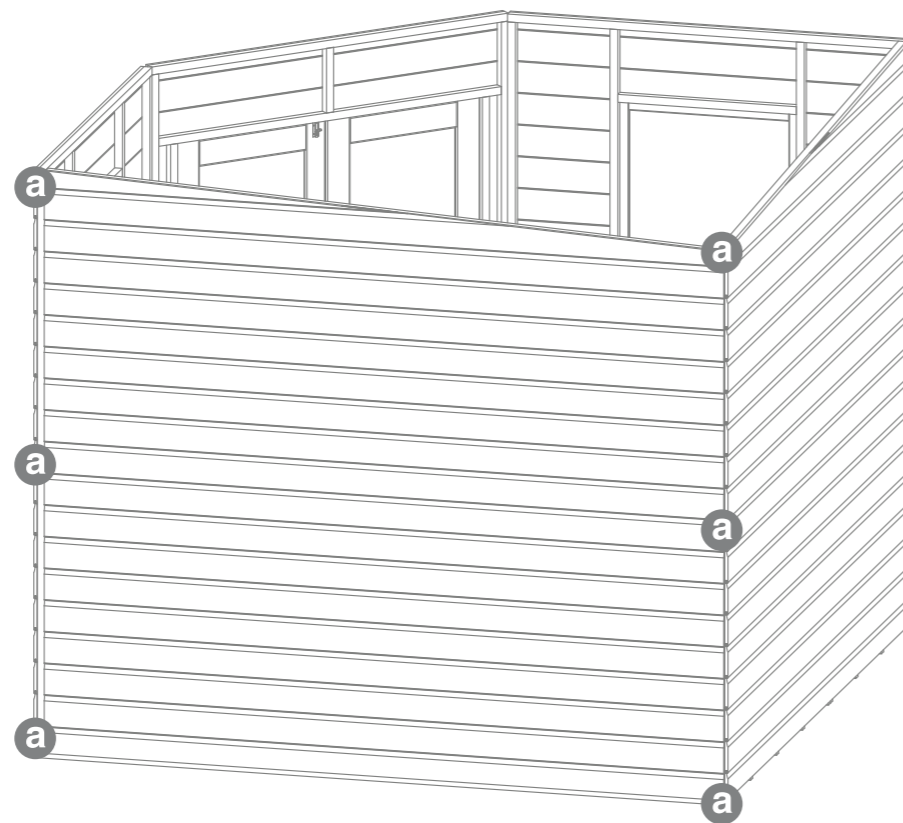
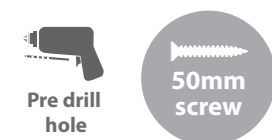

Step 6

First position the roof support bar in the centre of the building between the back corner and the door panel.

Ensure the top of the roof support bar runs level with building. Line the support block with the roof support & mark its position. Secure the roof block in place using 4x40mm screws. Screw through boards into the block from the outside.

Secure the front to the door panel using the "L" Bracket and 4x30mm Screws

4x30mm Screws
4x40mm Screws

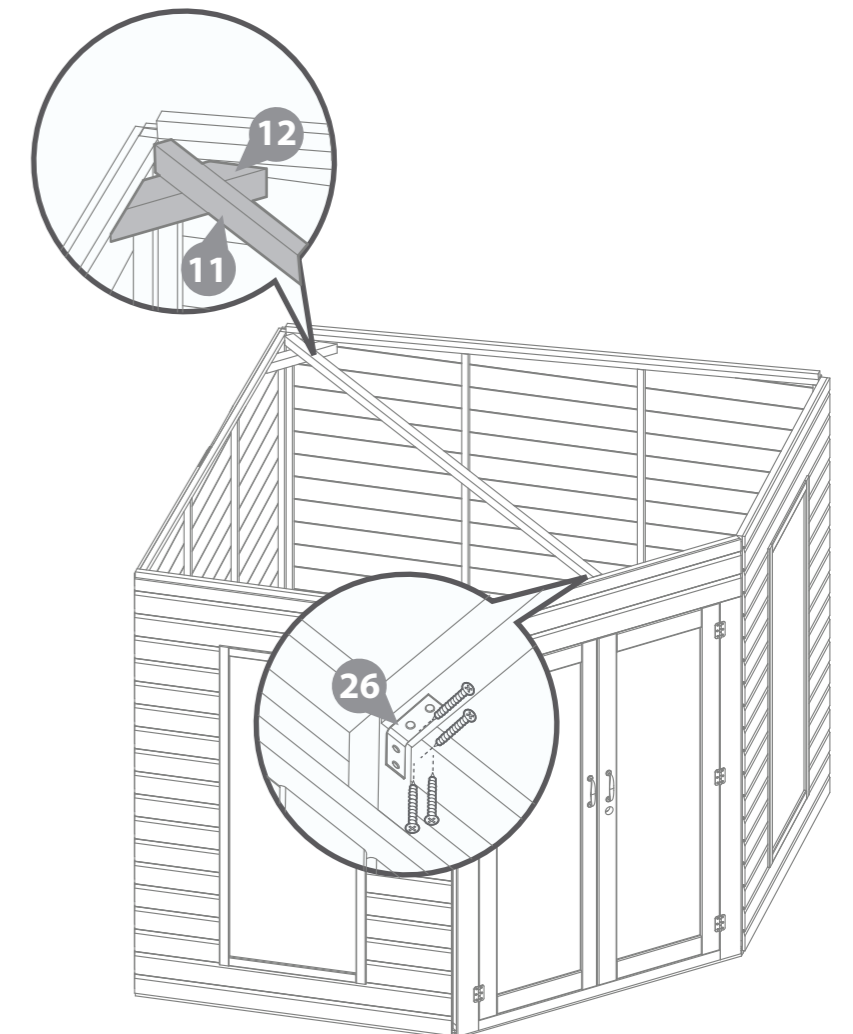

Step 7

layout the roof panels and position them as shown in diagram. Secure the panels together using 6x50mm screws.

* It is recommended to cut the roof felt sheets before fixing the roof to the building.

6x50mm Screws

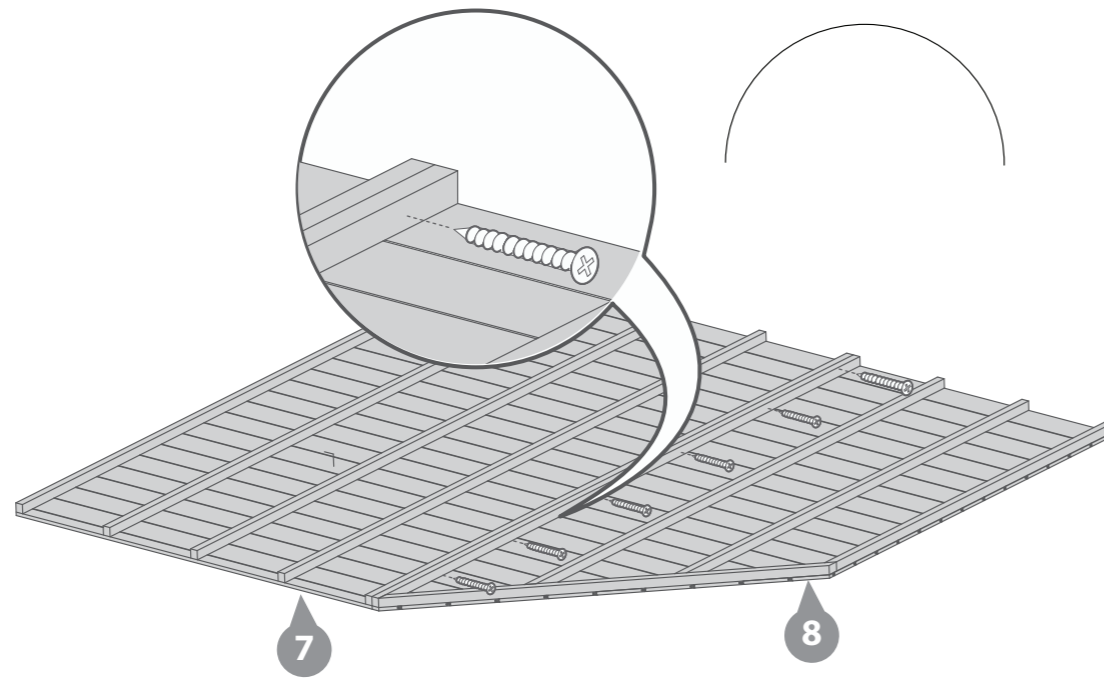

Step 9

Place both roof sections on top of building, ensure roof framing slots over each side equally all the way around.

Fix roof sheets into position using 40mm screws ensuring that they line up with the vertical framing inside the building and along the length of the internal roof support bar.

20x40mm Screws

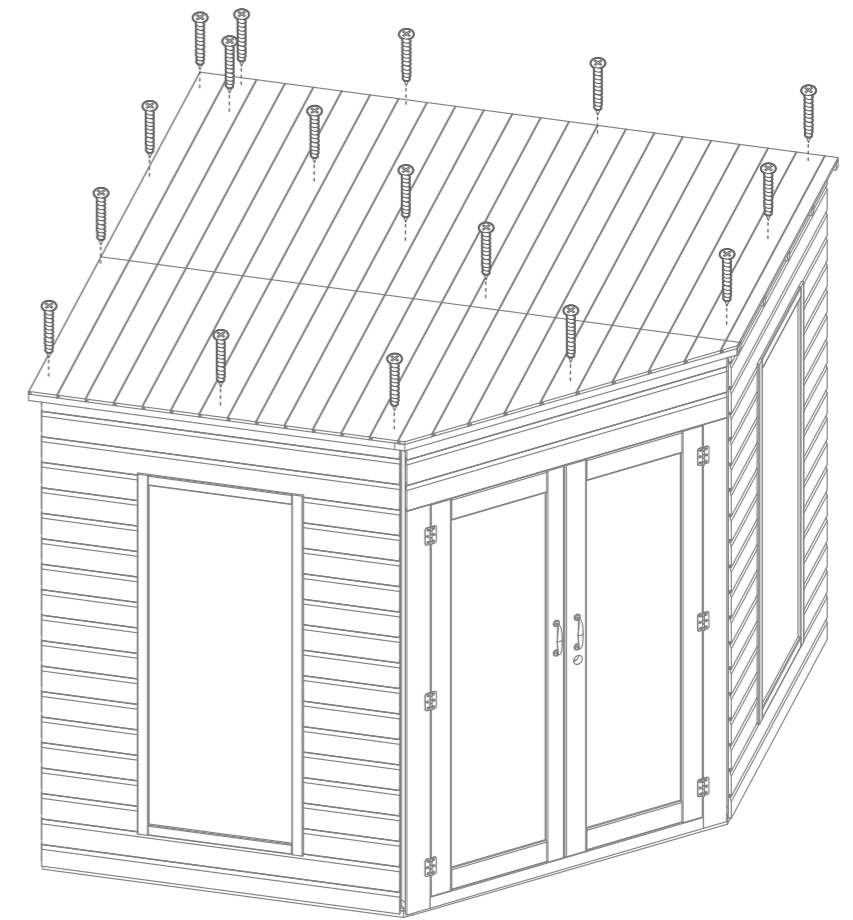
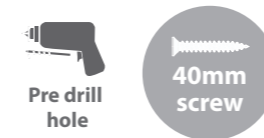

Step 8

Attach the front and rear roof framing to the roof as shown in the illustration using 6x30mm screws.

*Ensure to fix the framing the opposite direction to the roof bearers.

Fix the locating blocks to the opposing sides to the roof framing (these blocks are to help square the roof when fitted).

10x40mm Screws

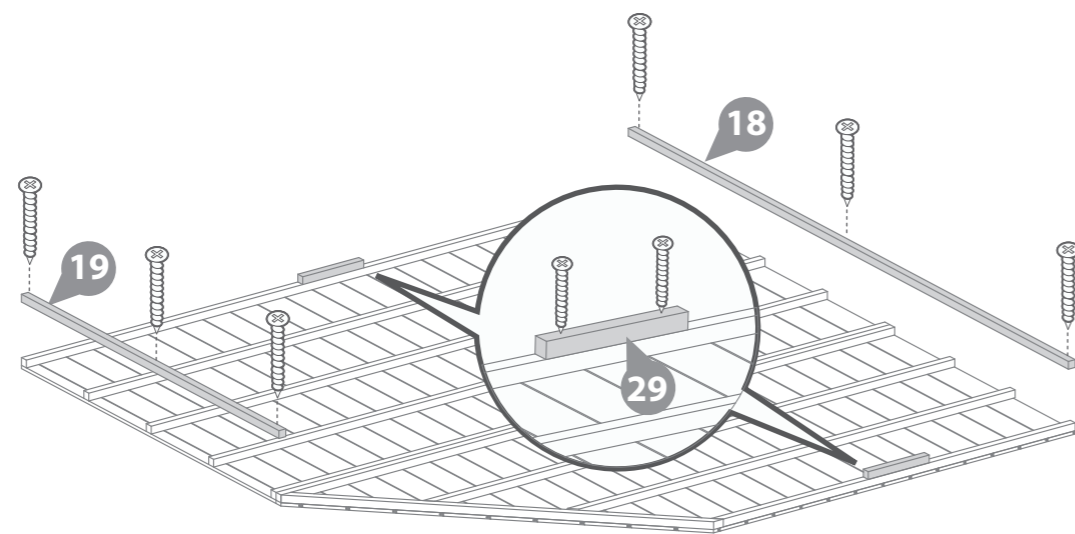

Step 10

Secure the building to the floor. Fix the panels 50mm screws in alignment with the floor joists.

20x50mm Screws

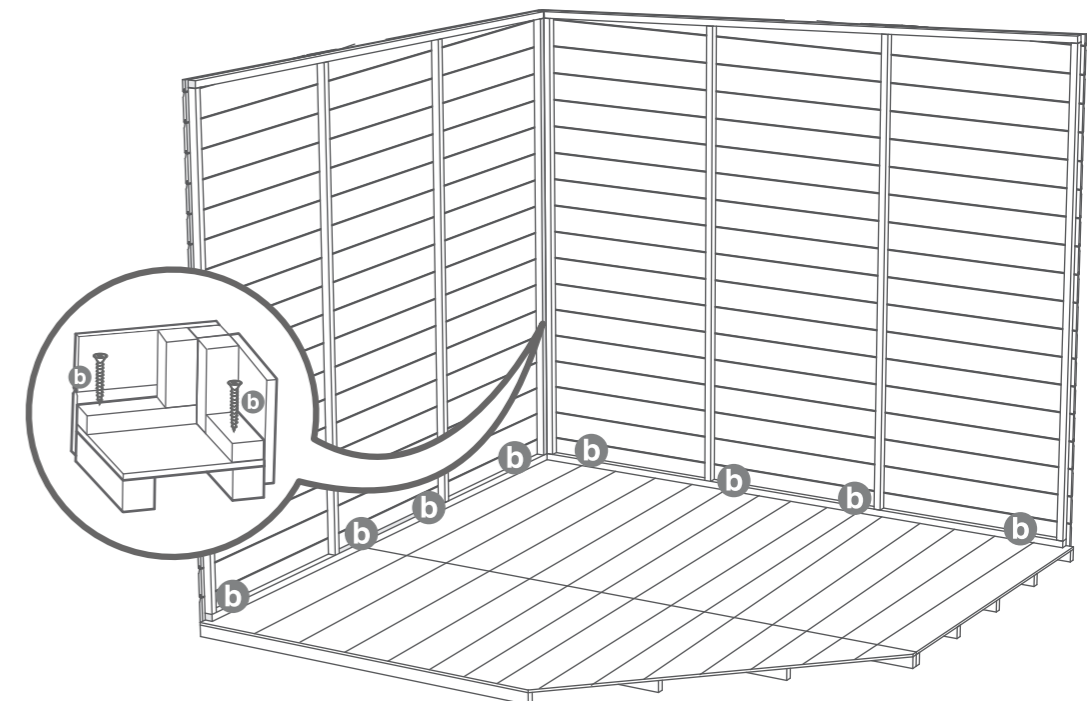
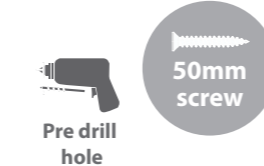

Step 11

Fix the cover trims to the front and side of the building using 3x40mm screws per strip.

12x40mm Screws



Step 13

Fit the fascias to the building over the felt and secure in place with 40mm screws.

17x40mm Screws

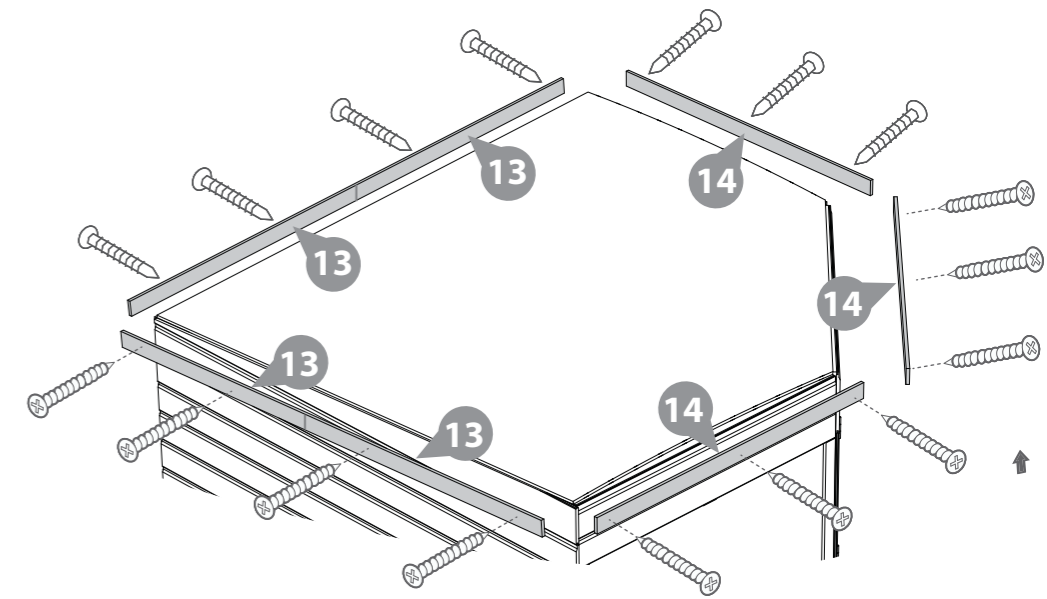

Step 12

Cut three strips from roll of felt, 2x370cm and 1x230cm.

With one of the 370cm strips, trim a corner off at 110cm to make piece 1.

Place felt on top of roof sheet and align as shown in diagram ensuring each strip overlaps the next by 20cm. Ensure all strips overhang roof by 5cm.

Ensure strip 1 is the first piece placed down then lay sheet 2, 3 and then 4 on top.

Cut the sides as shown in diagram at the dotted lines, use fascia width as guide for overhang. Cut Triangle with 50mm overhang again using fascia as a guide.

Fix each sheet using felt tacks along where sheet overlap.

100x Felt Tacks

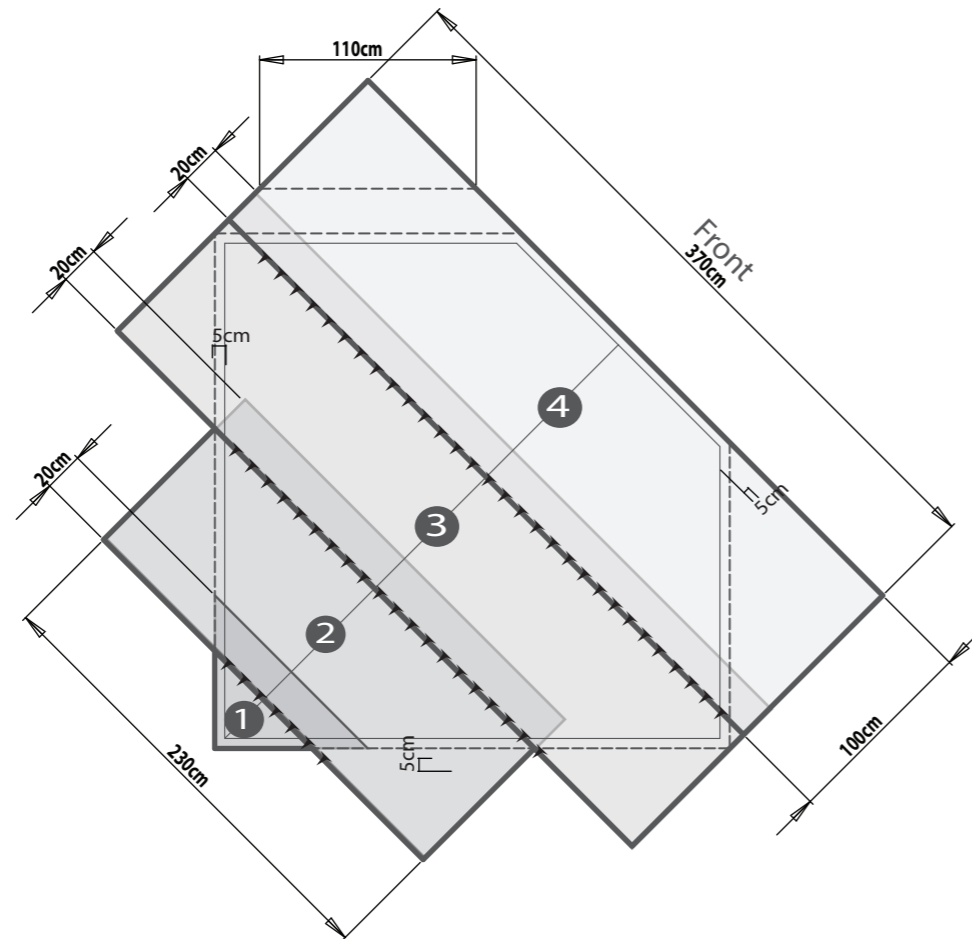

Step 14

Attach the two turn buttons to the top and bottom of the slave door with 1x16mm black screw per turn button.

* These turn buttons help to keep your doors straight during high and low levels of moisture content in the air.

2x16mm Black Screws

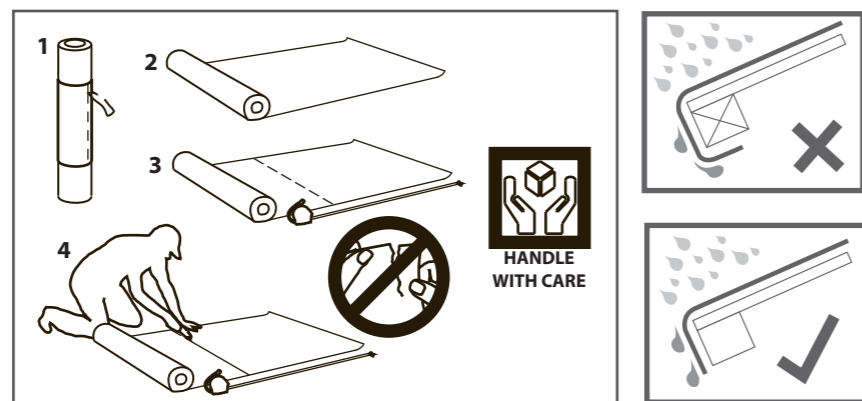
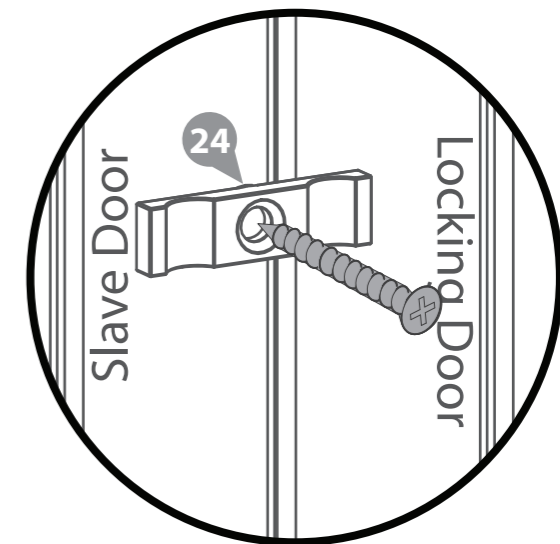

Step 15

Attach the rain guards to the building, fixing in place above each window using 3x60mm screws per guard.

6x60mm Screws

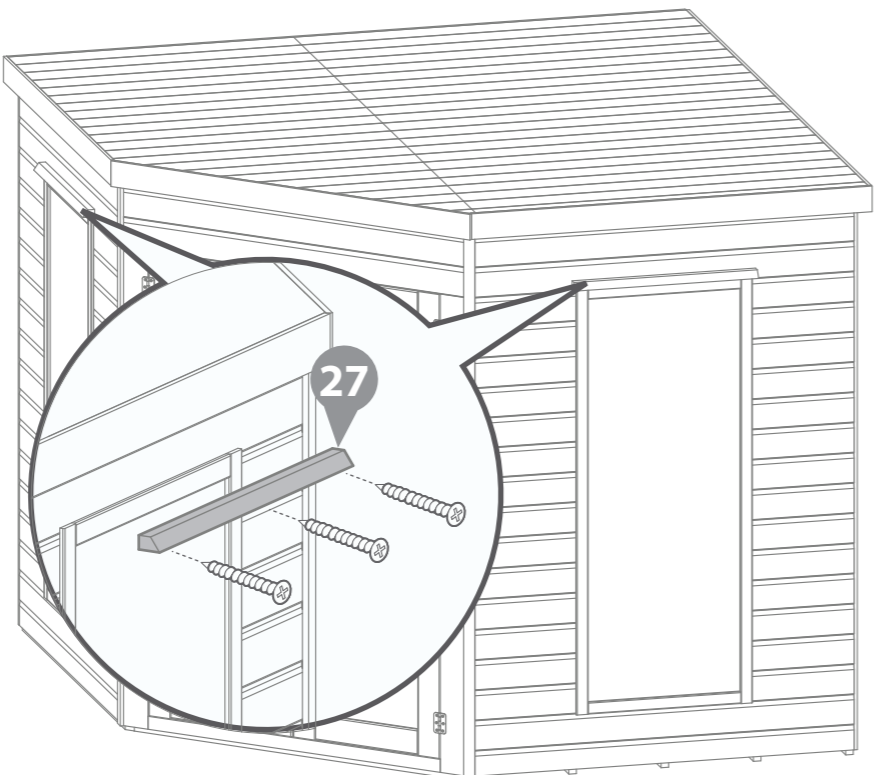

Step 17

Attach the larger rain guard above the doors, fixing in place using 3x60mm

3x60mm Screws

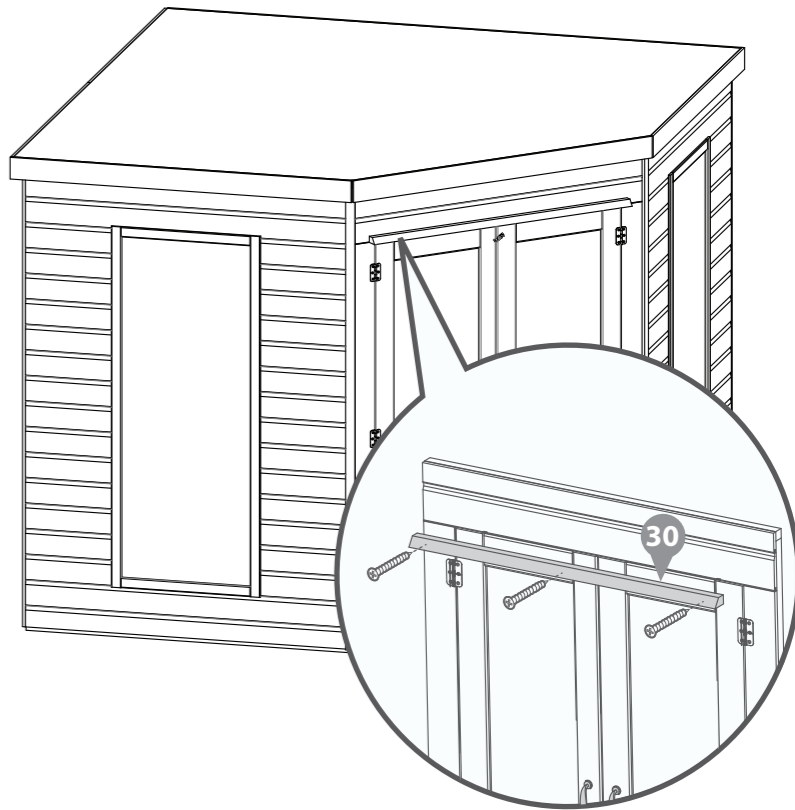

Step 16

Fix the rear cover trimsto the back of the building, aligning with the edge of the panel.

6x40mm Screws

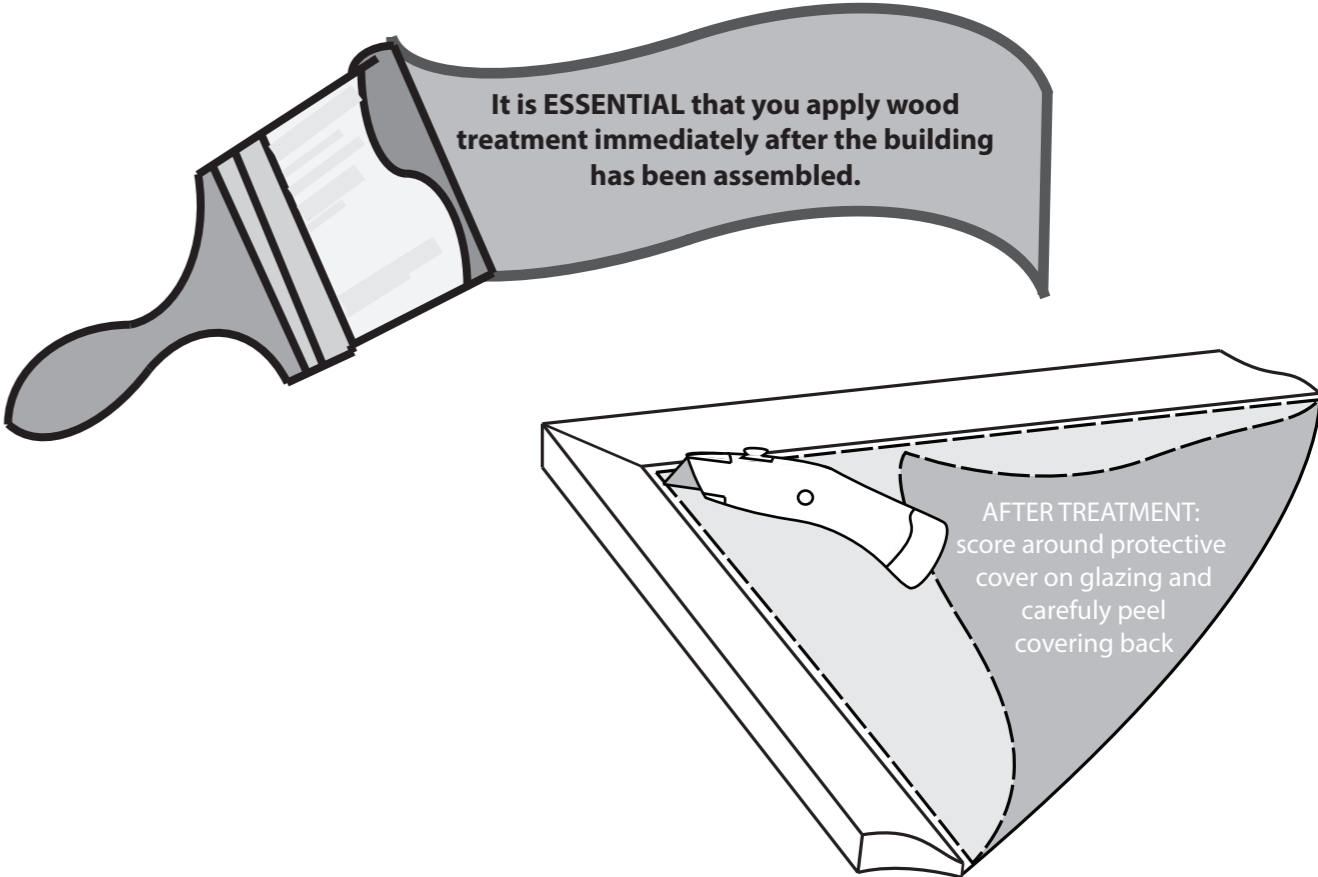
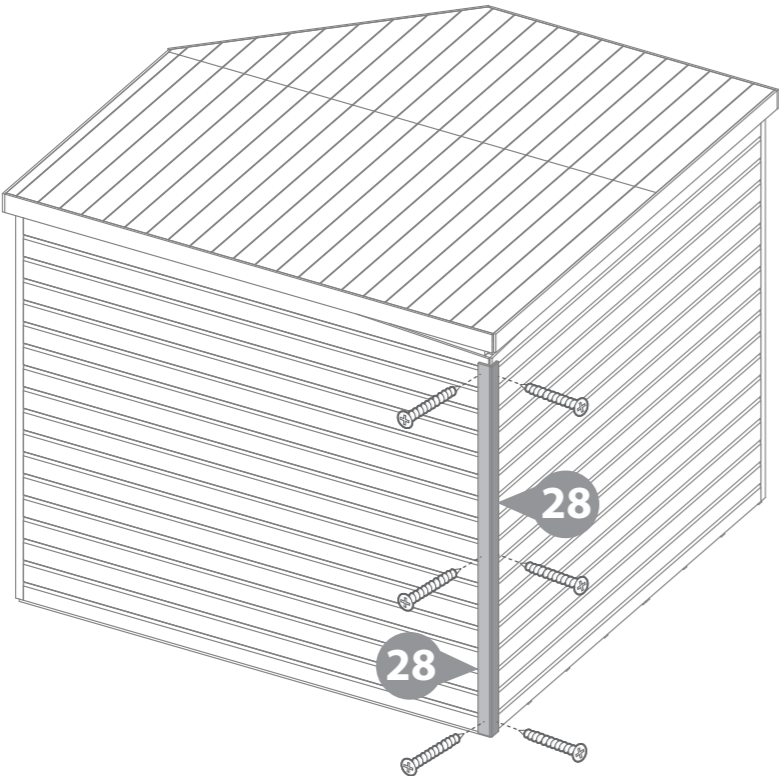

It is ESSENTIAL that you apply wood treatment immediately after the building has been assembled.

AFTER TREATMENT: score around protective cover on glazing and carefully peel covering back